

HARDWARE LIST

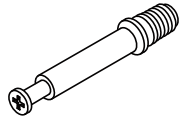

6 x A
Quickfit Screw



6 x B
Cam Lock



12 x C
Wooden Dowel

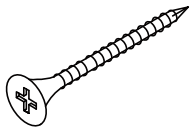

14 x D
Screw

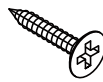

2 x E
Screw

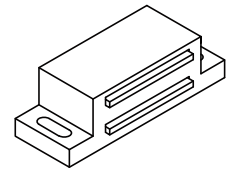

1 x F
Magnet

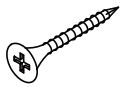

10 x G
Screw

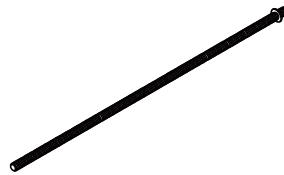

1 x H
Rebar Bolt

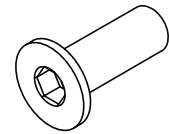

1 x I
Bolt

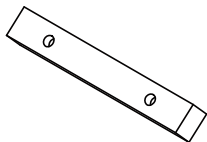

1 x J
Handle

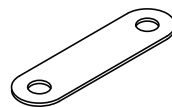

1 x K
Bracket



2 x L
Screw

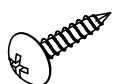

6 x M
Screw

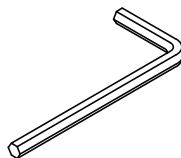

1 x O
Allen Key



1 x P
Washer

PARTS LIST

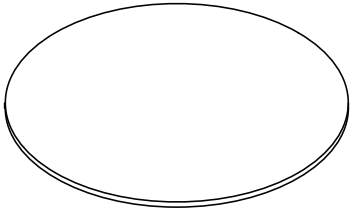

1
1 PC

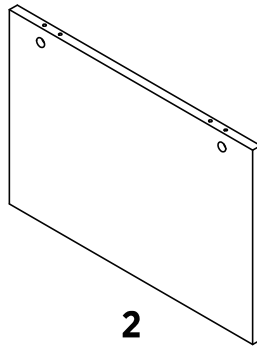

2
1 PC

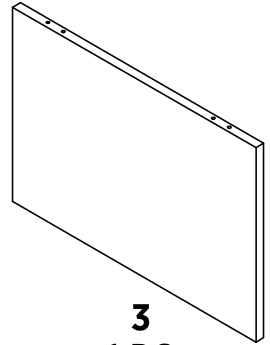

3
1 PC

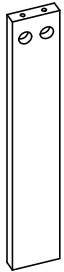

4
1 PC



5
1 PC

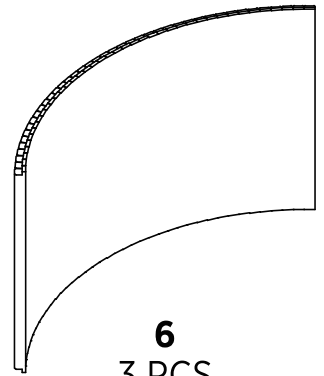

6
3 PCS

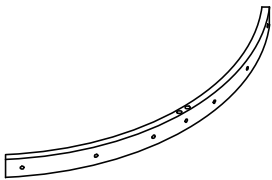

7
1 PC

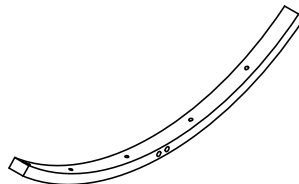

8
1 PC

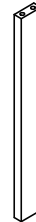

9
1 PC

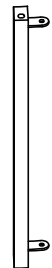

10
1 PC



11
1 PC

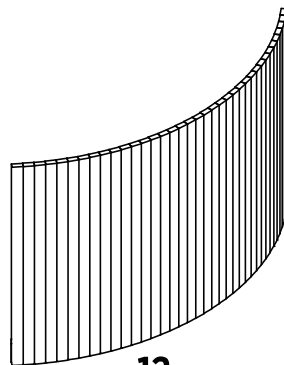

12
1 PC

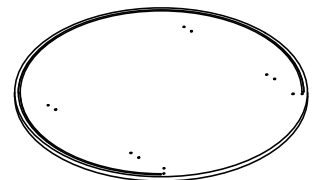

13
1 PC

STEP 1

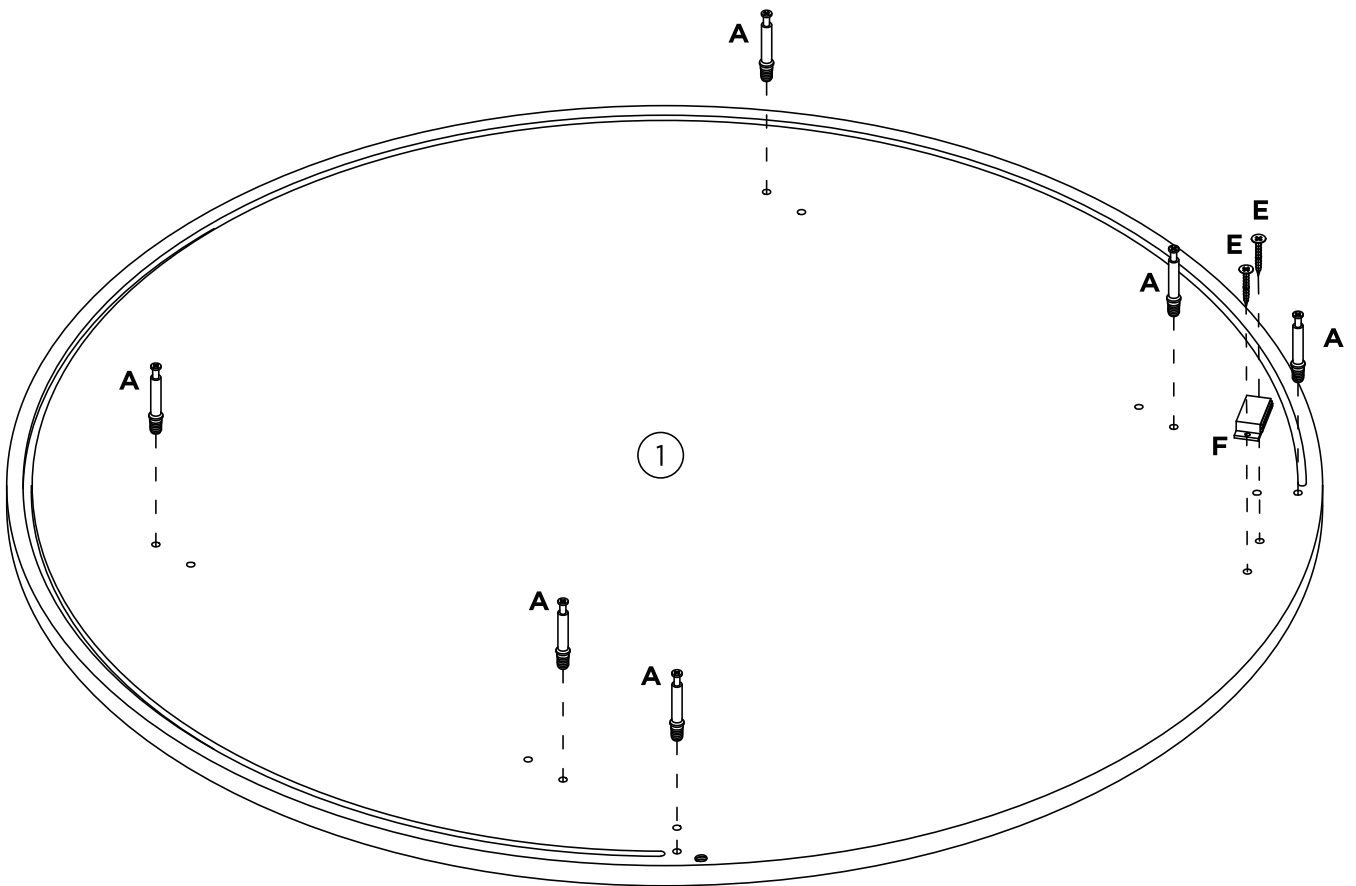
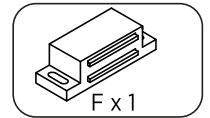
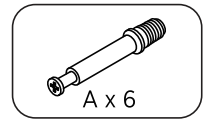

STEP 2

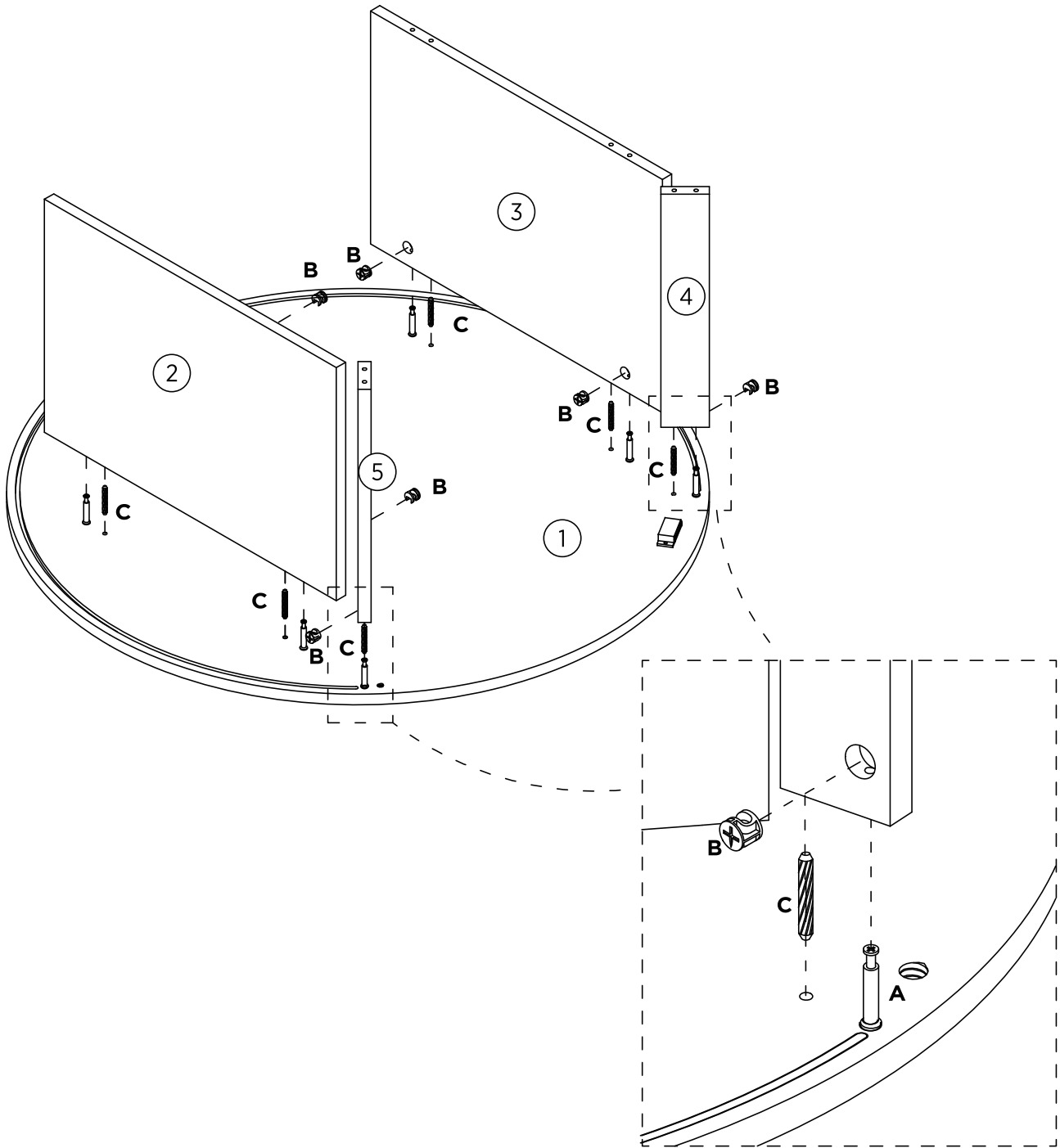
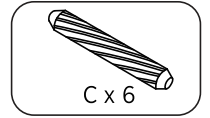

STEP 3

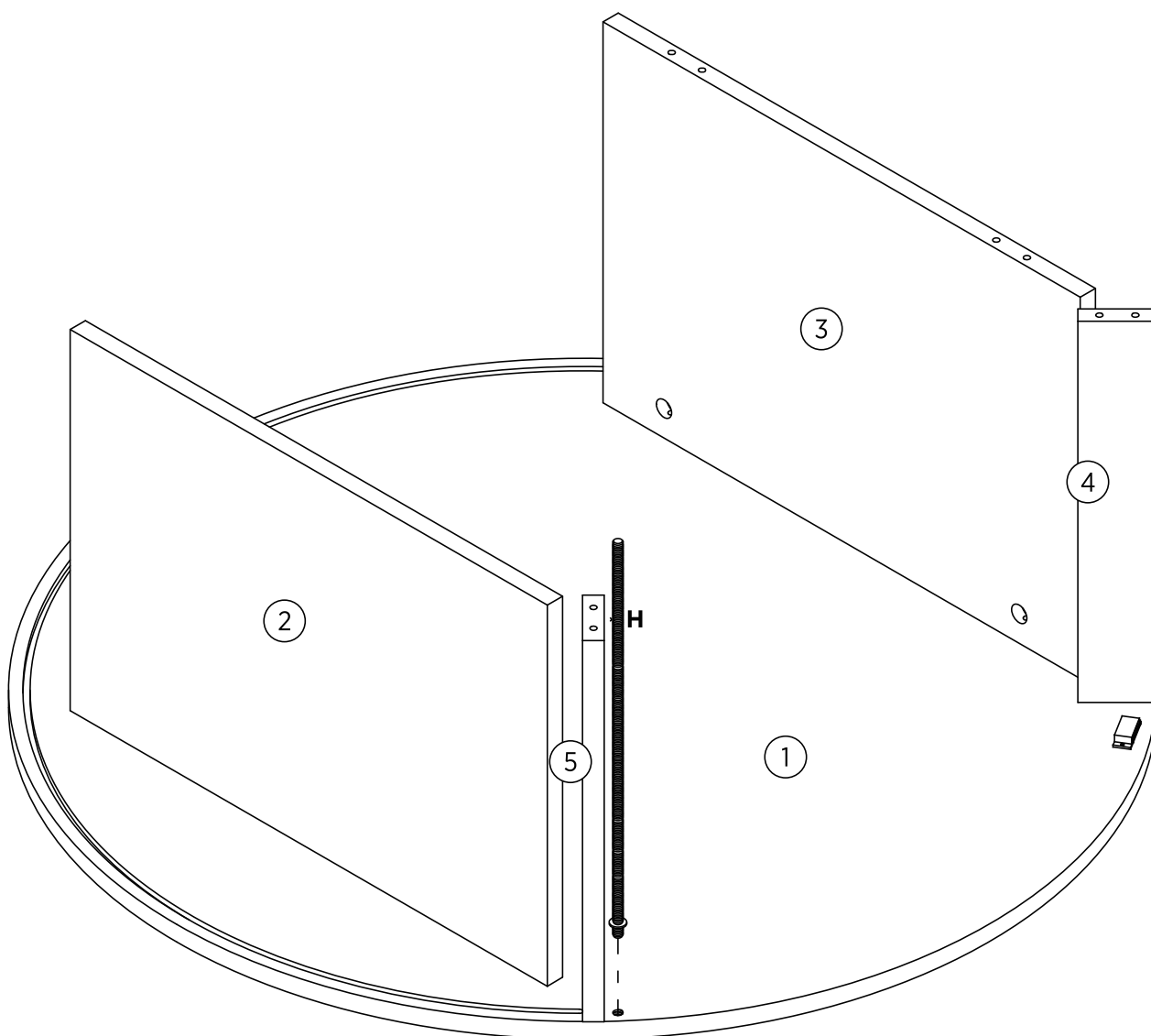
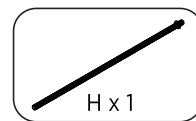

STEP 4

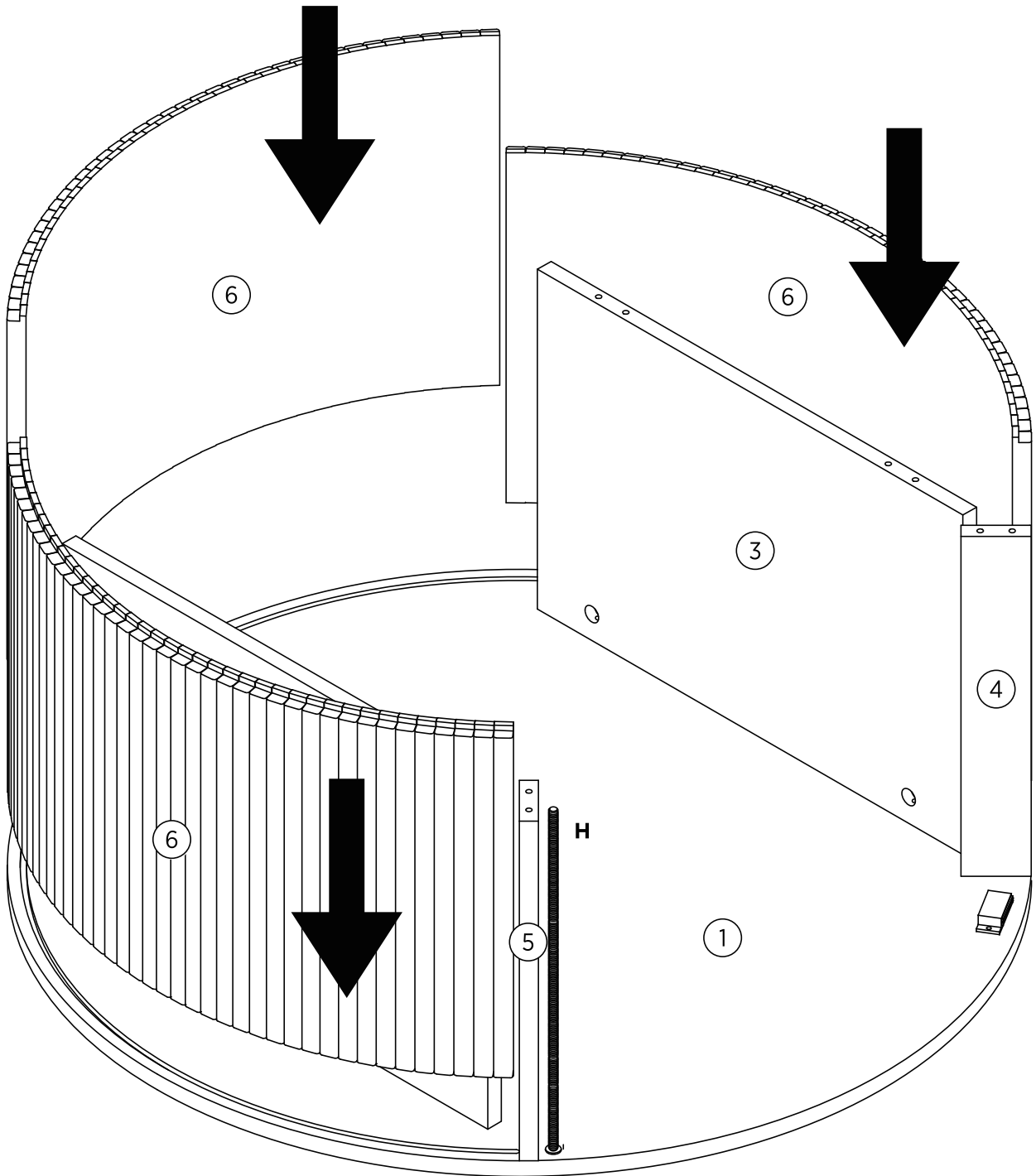

STEP 5

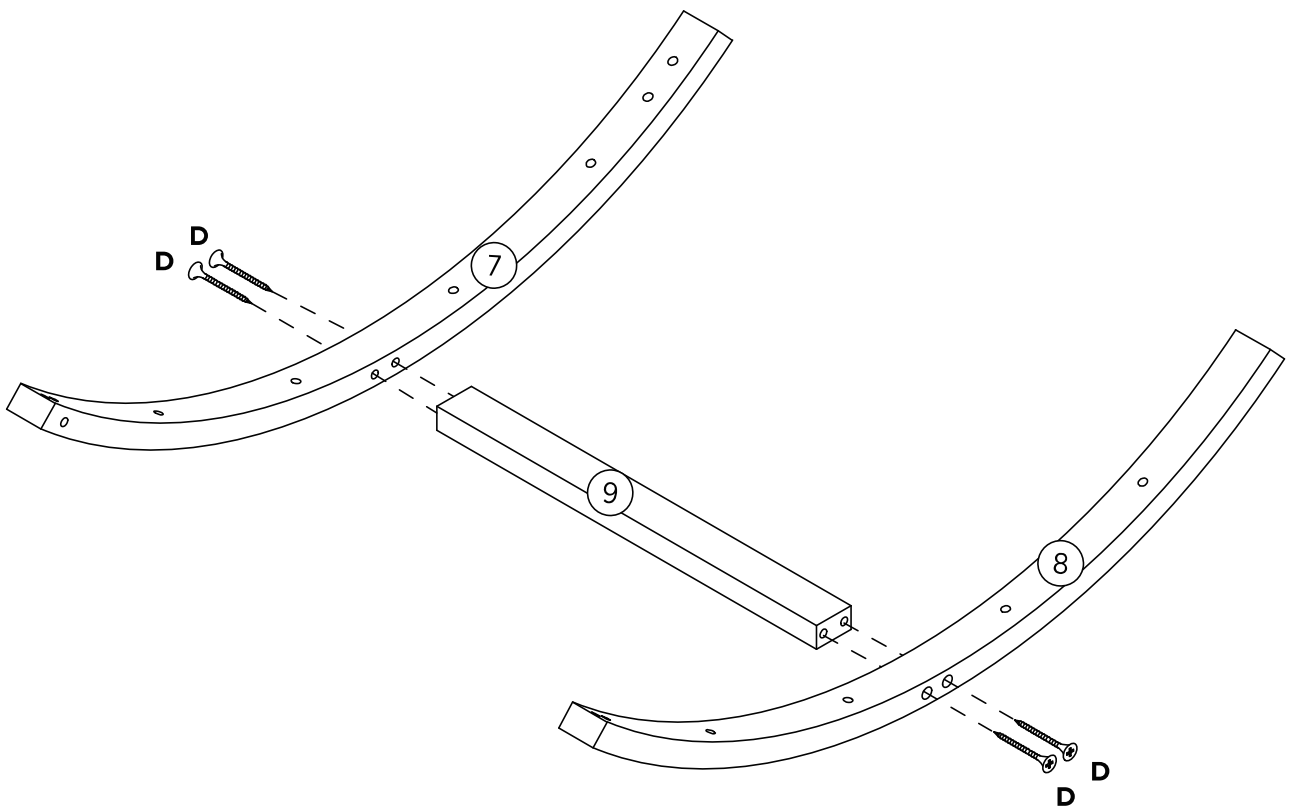
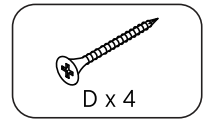

STEP 6

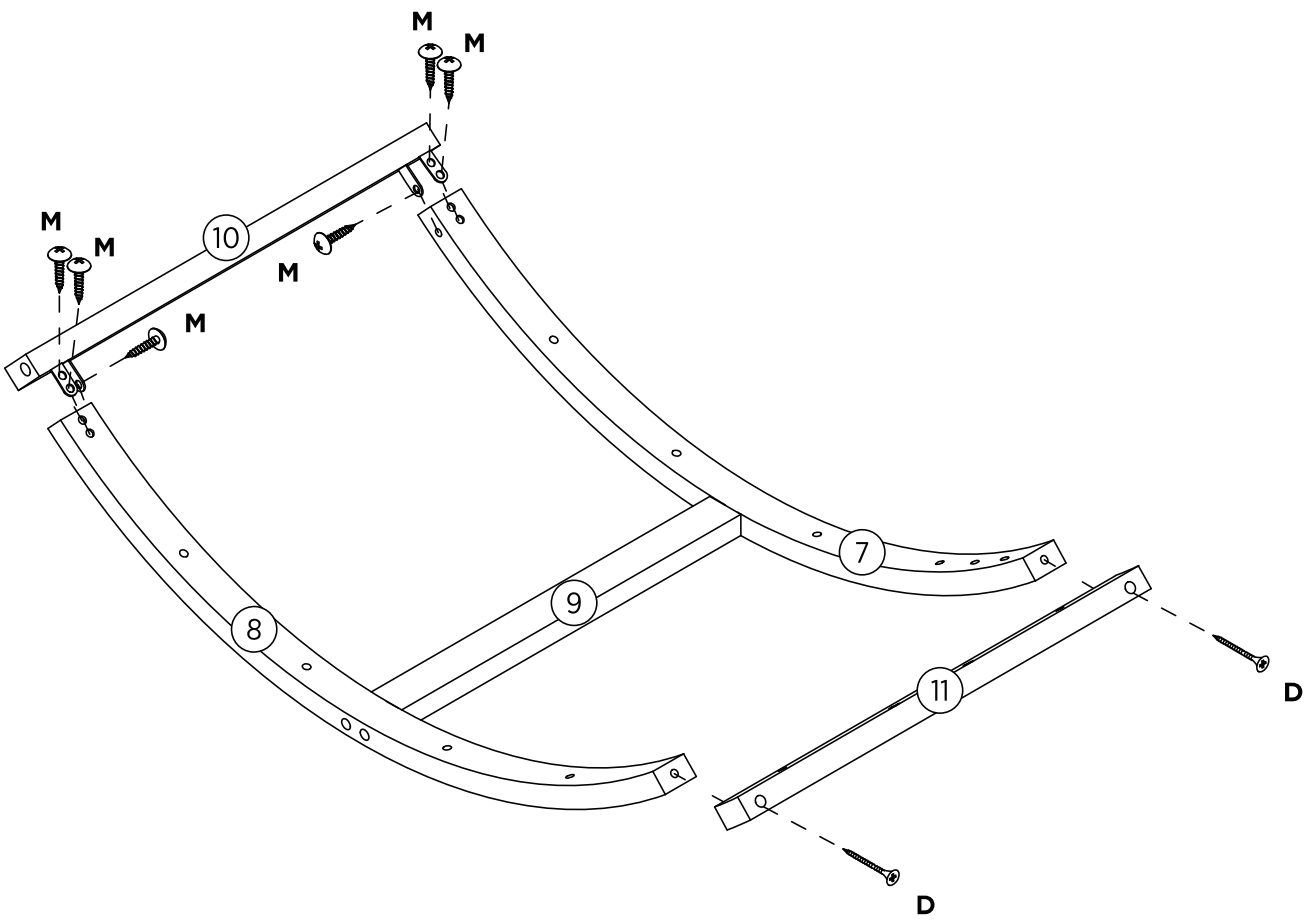
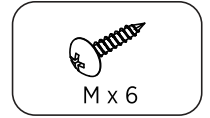
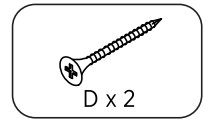

STEP 7

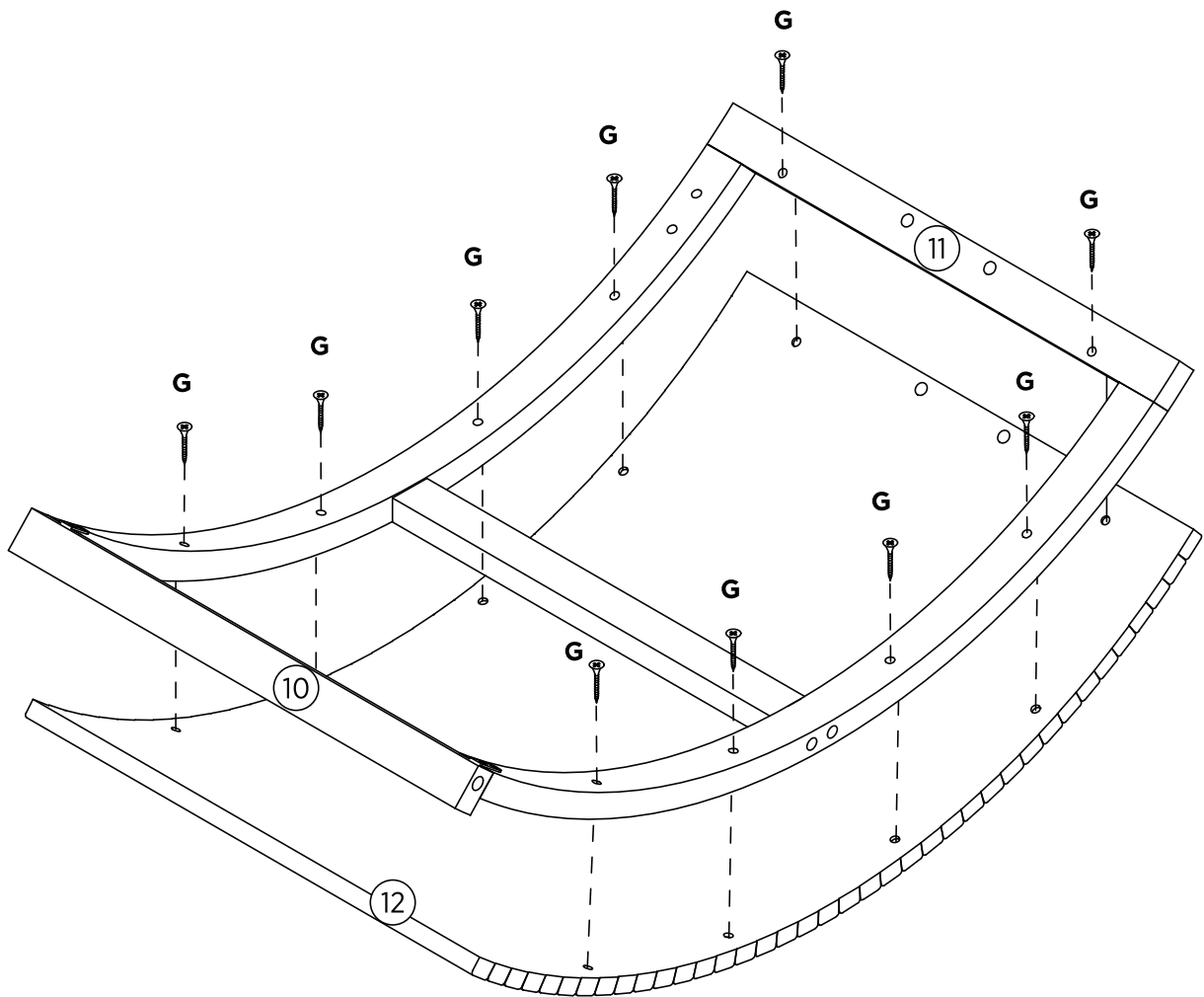
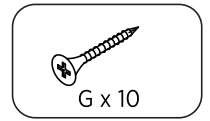

STEP 8

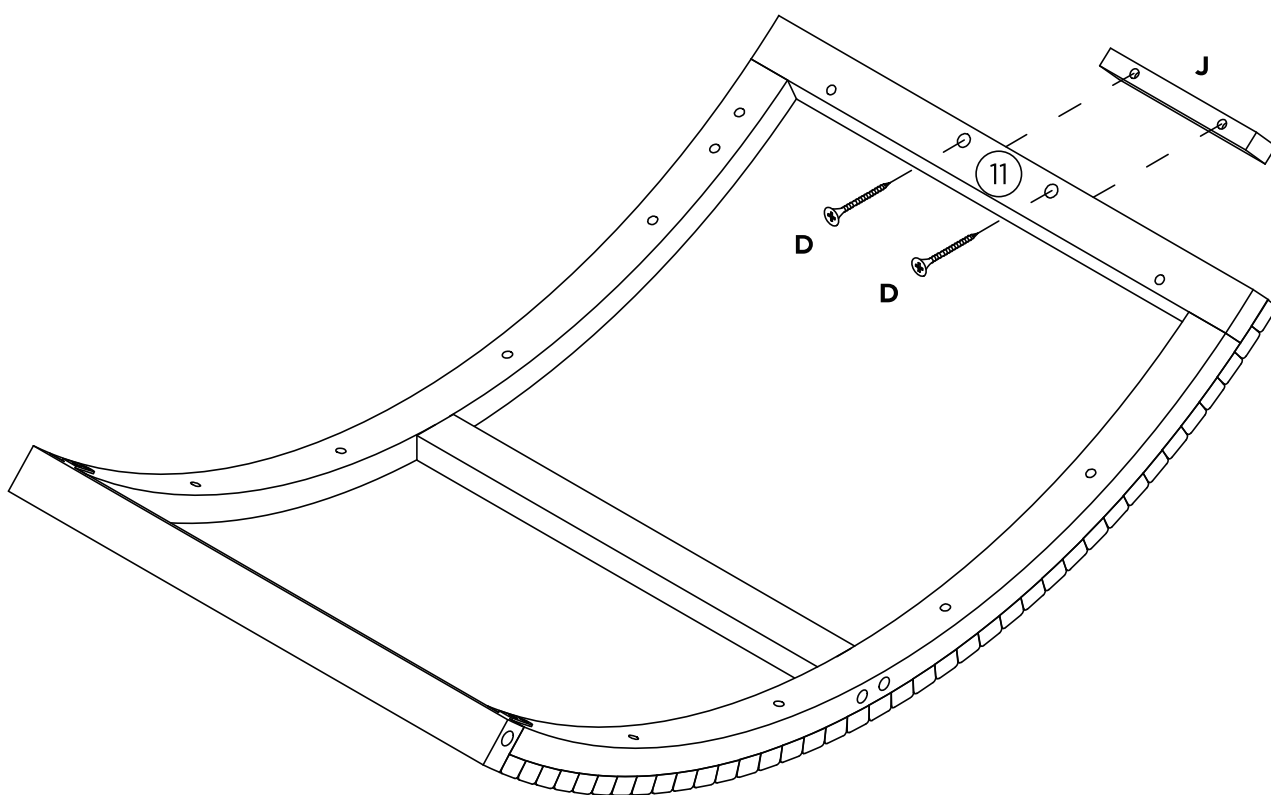
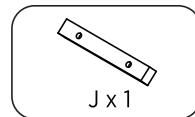
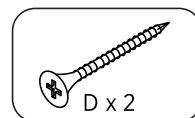

STEP 9

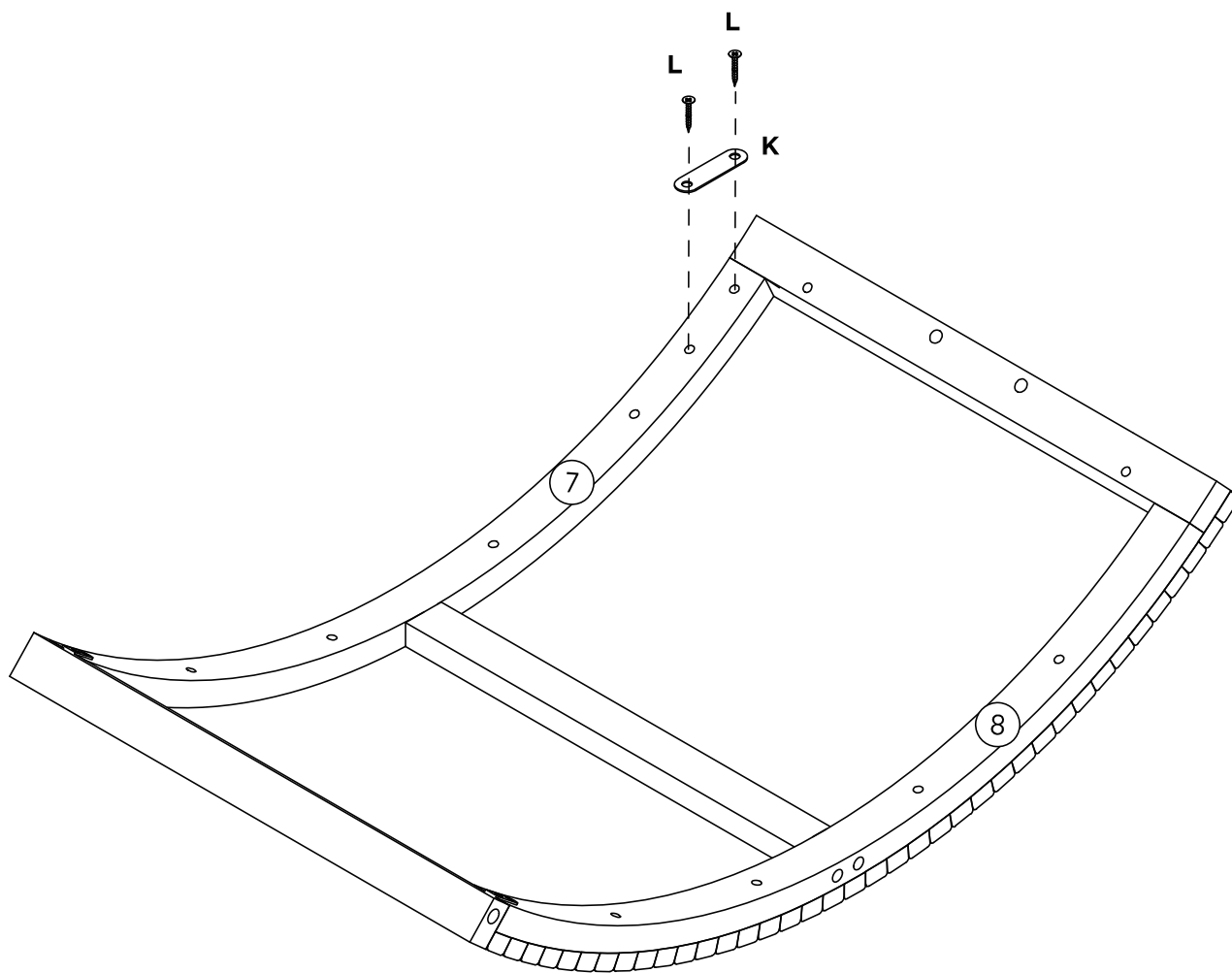
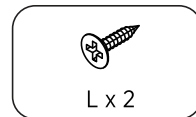
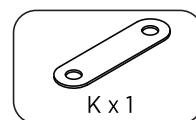

STEP 10

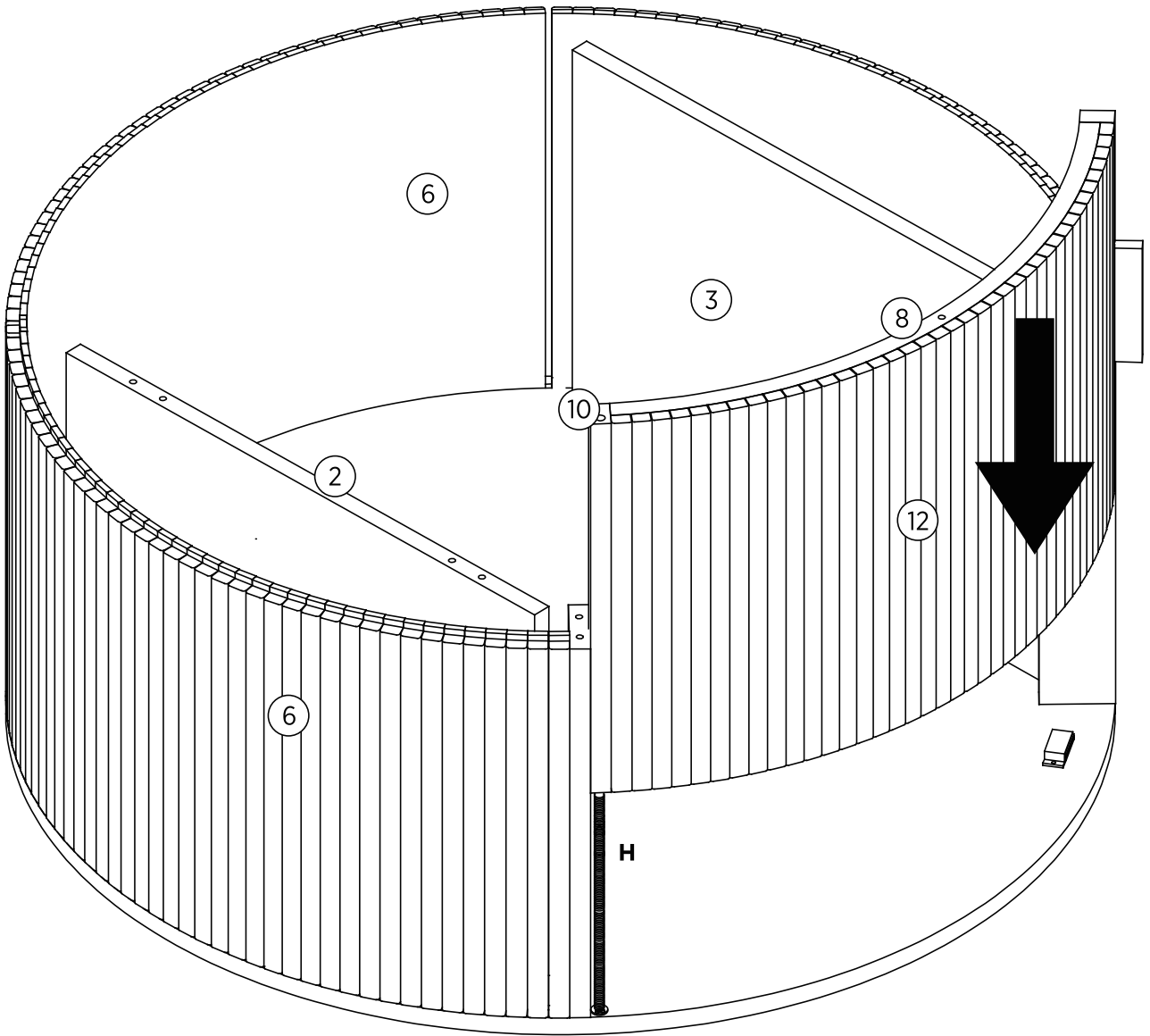

STEP 11

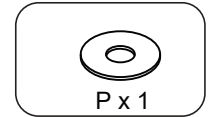
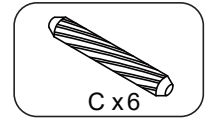
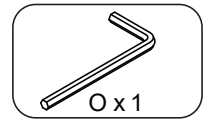
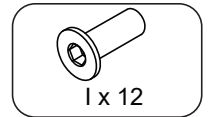
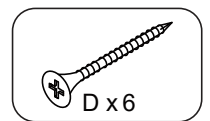
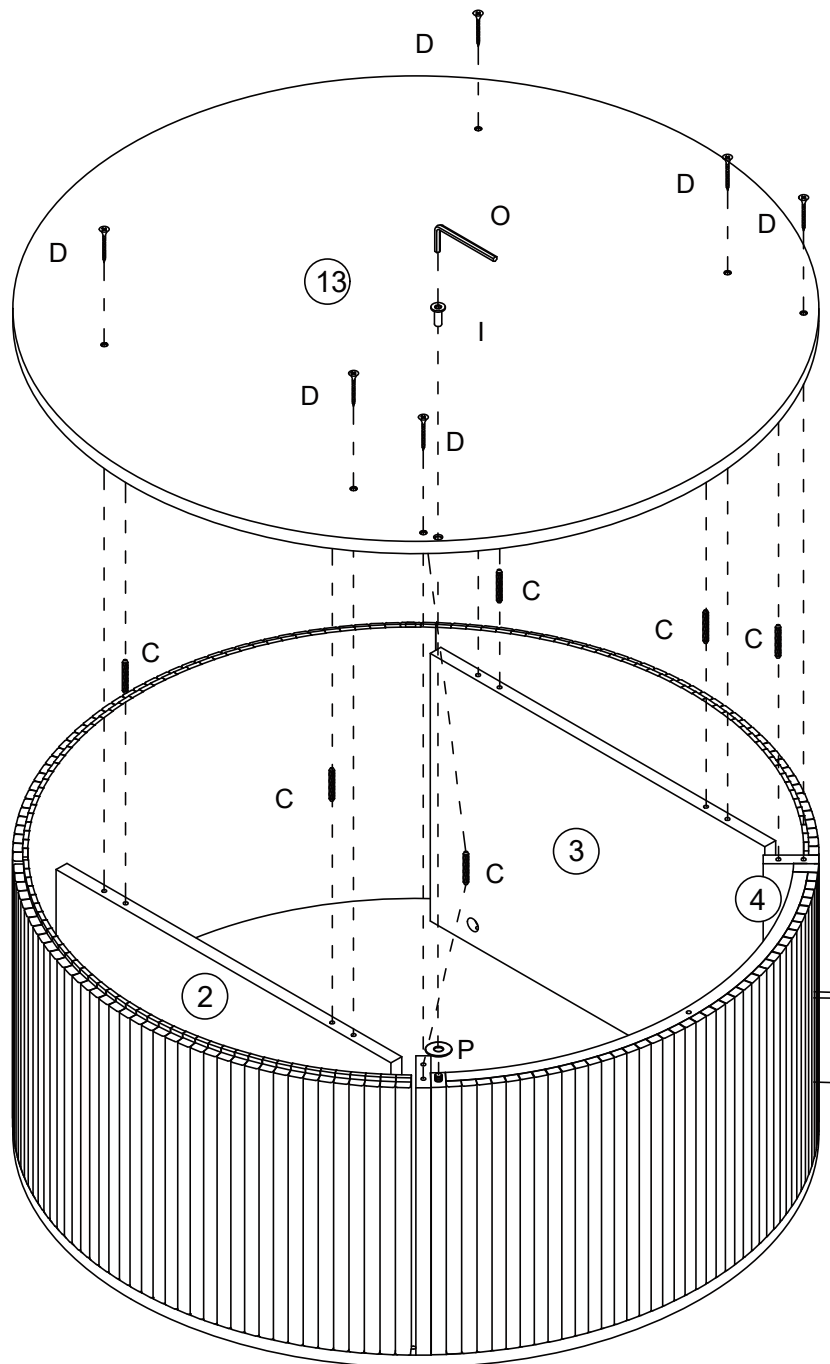

STEP 12

