

BRABANTIA 79CM TOWER FAN

Instruction Manual
BBEC4022A

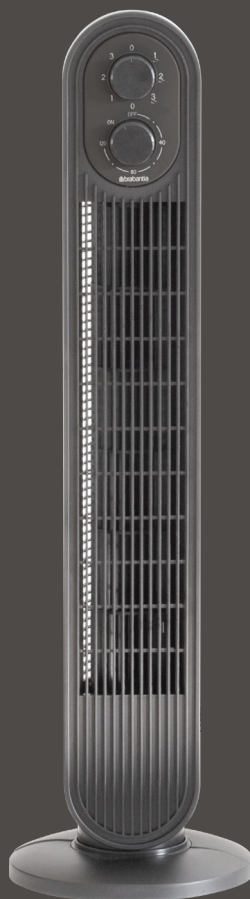

www.brabantia.com/electrical-appliances

 **brabantia**



THANK YOU FOR PURCHASING OUR 79CM TOWER FAN

We hope it will delight you and that it will get a special place in your home. Enjoy!

IMPORTANT SAFEGUARDS

Please read these instructions carefully and keep them for future reference. When using this appliance, basic safety precautions should always be followed, including but not limited to the following:

1. This appliance is not intended for use by persons (including children) with reduced physical, sensory or mental capabilities, or lack of experience and knowledge, unless they have been given supervision or instruction concerning use of the appliance by a person responsible for their safety.
2. Children should be supervised to ensure that they do not play with the appliance.
3. If the supply cord is damaged, it must be replaced by the manufacturer, its service agent, or similarly qualified persons to avoid a hazard.
4. Use only the voltage specified on the rating plate of the appliance.
5. Keep all objects at least 1 metre from the front, sides and rear of the appliance
6. This appliance is intended for household use only and not for commercial or industrial use.
7. Only use this appliance only as described in this manual. Any other use is not recommended by the manufacturer and may cause fire, electric shock or injury.
8. The common cause of overheating is deposits of dust or fluff in the appliance. Ensure these deposits are removed regularly by unplugging the appliance and vacuum cleaning the air vents and grills.
9. Always unplug appliance when not in use.
10. When the appliance has been unpacked, check it for transport damage and ensure all parts have been delivered. If parts are missing or the appliance has been damaged, contact the retailer you purchased this product from or the New Zealand Brabantia Agent, toll free number 0800 127 727.
11. If your appliance does not work, or is not working properly, contact the place of purchase. Repair work on the appliance by unqualified persons can cause serious risk to the user.
12. Ensure hands are dry before handling the plug or the main unit.
13. Carry out regular checks of the supply cord to ensure no damage is evident.
14. Ensure that the cord is fully extended (not coiled) while in use.
15. Avoid contact with the moving parts. Keep hands, hair, clothing, away from blade of the fan during operation to reduce the risk of injury to person and/or damage to the unit.
16. Switch off and use the handle on the back when moving.
17. It is recommended that this fan is plugged directly into the wall socket.
18. A correctly specified, undamaged extension cord may be used with this fan provided it is used in a safe manner.
19. Never place appliance close to radiant heat source.
20. Never operate in areas where petrol, paint or other flammable liquids are used or stored.
21. Never use the appliance to dry clothes.

22. Never insert or allow foreign objects to enter any ventilation or exhaust opening, as this may cause an electric shock, fire or damage to the appliance.
23. Never use abrasive cleaning products on this appliance. Clean with a damp cloth (not wet) rinsed in hot soapy water only. Always remove plug from the mains supply before cleaning.
24. Never connect the appliance to mains supply until completely assembled and adjusted.
25. Never remove plug from power socket until the appliance has been switched off.
26. Never remove plug from power socket by pulling cord – always grip the plug.
27. Never twist, kink or wrap the cord around the appliance, as this may cause the insulation to weaken and split. Always ensure that all cord has been removed from any cord storage area and is unrolled before use.
28. Never use this appliance in the immediate surrounds of a bath, a shower, or a swimming pool or other liquids. The appliance must not be immersed in any liquids.
29. Due to the risk of injury, never use this appliance for any purpose other than its intended use. This appliance is intended for use in household and similar applications such as staff kitchen areas in shops, offices and other working environments, farmhouses, by clients in hotels, motels, bed and breakfast type environments and other residential type environments.
30. Never use this appliance outdoors.
31. Never operate the appliance with a damaged cord or plug, after it malfunctions, or if it has been damaged in any manner. Have the appliance checked and repaired by a qualified electrician if repair is necessary.
32. Never place the unit in wardrobes or other enclosed spaces as this may cause fire hazards.
33. Store fan in a clean dry place when not in use.
34. **WARNING:** To reduce the risk of fire or electrical shock, do not use this fan with any solid-state speed control device.

IMPORTANT SAFETY MEASURES

Please ensure that the voltage of the fan corresponds to the mains voltage.

- Use the fan only for the purpose(s) defined in the user guide.
- Never insert your fingers, pencils or other objects through the fan cage during operation.
- Switch the fan off and unplug from mains power supply before moving or cleaning.
- The fan should be set up on a stable and level surface to avoid it being knocked over.
- Do not expose the fan to excessive heat or humidity, as this can cause damage to the electrical components.
- Do not immerse in any form of liquid.
- It is not advisable to expose people, in particular babies and the elderly, to a continuous stream of cold air.
- The fan should be kept out of reach of children.
- Ensure that the cable does not get caught beneath the device, in drawers, behind shelves etc.
- Do not run the cable under carpets, rugs, etc.
- Ensure the cable is kept away from busy areas to avoid anyone tripping over it.
- Do not use if the device or cable becomes damaged. Take it to a specialist for repair.
- For indoor use only.

ASSEMBLY INSTRUCTIONS

Do not operate the tower fan without the base. The tower fan base composes of two pieces, front base D and rear base E.

Step 1: The base needs to be connected together.

Step 2: To mount the base, follow the steps below. Place power cord in the round hole between base D and base E. Then assemble the 2 bases using the snap joints in the centre join. Put the power cord through the slot of the base.

Step 3: Position the fan body onto the base using the 4 holes in the base, make sure the snaps between body and base are secure and stable.

NOTE: Before assembling the base, make sure the power cord is through the hole between the 2 bases

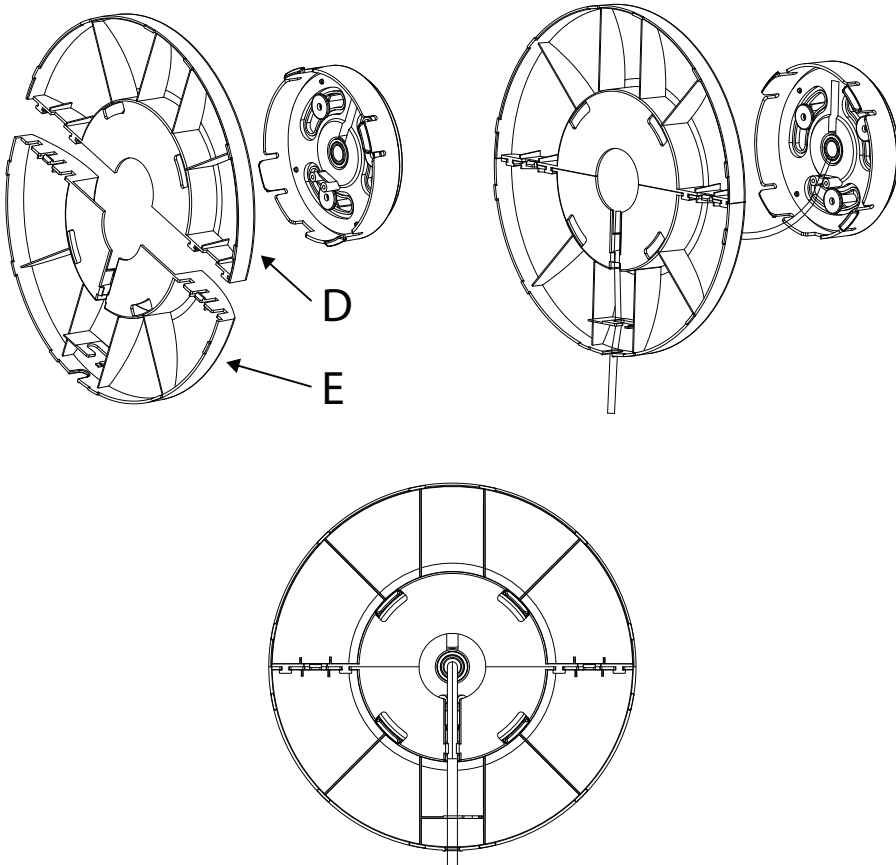

KNOW YOUR TOWER FAN

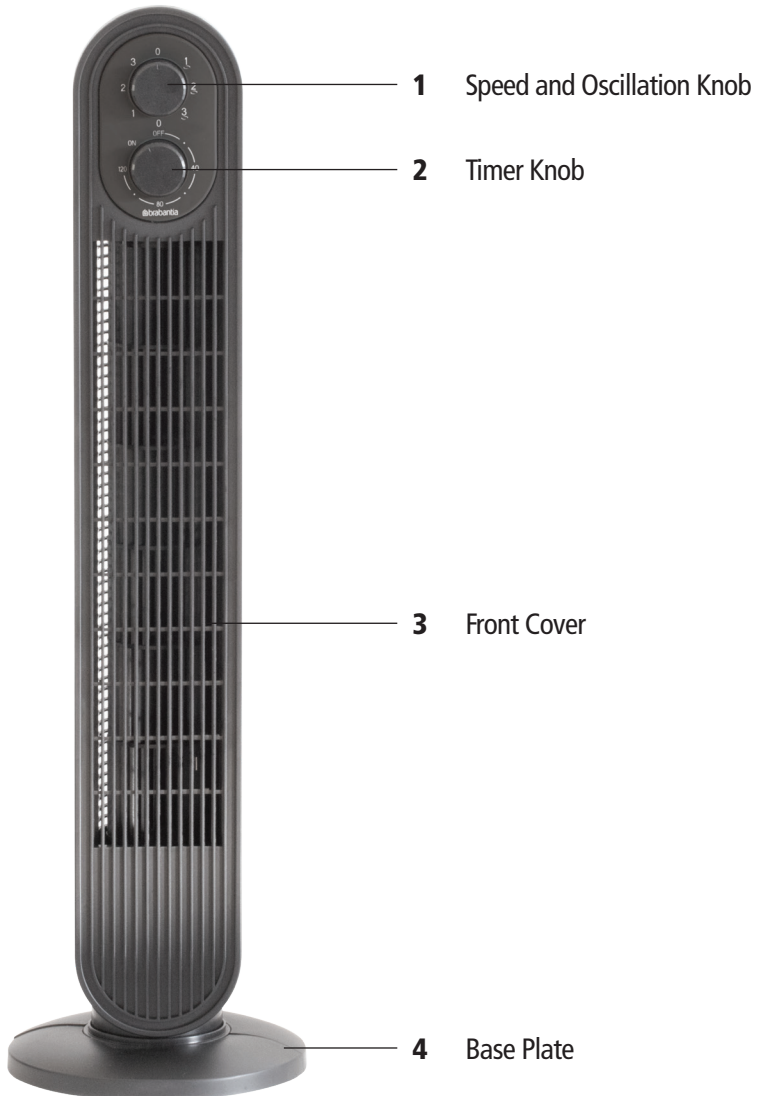

USING YOUR FAN

Before each use, check the unit is in good condition and the electric cord is not damaged. If the power cord is damaged, it must be replaced by the manufacturer or a competent qualified electrician or a person with similar qualifications, in order to avoid any risk of electrocution.

TIMER

This tower fan has a timer that automatically switches off the fan at the end of the time set.

To set the time turn the timer knob (A) clockwise to the position corresponding to the desired operating time (0-120 min.).

The fan can also operate continuously without the use of the timer.

Turn the timer knob anticlockwise to the "ON" position.

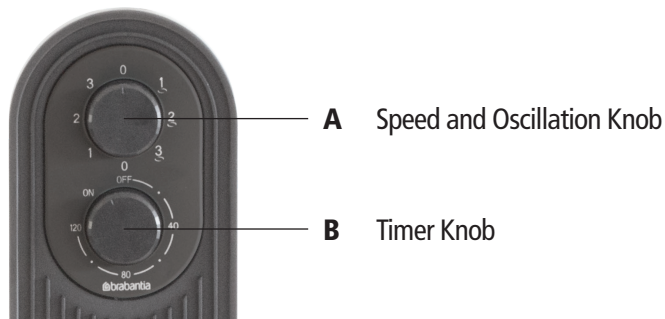

SPEED AND OSCILLATION

After setting the timer (B) and to start the fan, turn the speed and oscillation knob (A)

0 = Off

1 = Minimum speed

2 = Medium speed

3 = Maximum speed

1 = Minimum speed and oscillating

2 = Medium speed and oscillating

3 = Maximum speed and oscillating

To switch off the appliance, turn the speed switch knob (B) to the "0" position or turn the timer knob (A) to the "OFF" position, and then remove the plug from the socket.

TROUBLESHOOTING

Problems and Solutions

Symptom	Check for Solution
The fan does not run when the power is on	Check if the power lead is correctly plugged into the socket and the power is on. Check if the power cord is completed.
There is an abnormal sound when starting up	Check if any foreign matter has entered the body and/or foreign matter has jammed the fan.
WARNING: If the power cord is damaged, in order to avoid danger, it must be replaced by a certified electrician.	

CLEANING AND STORAGE

- Always turn off the power supply and unplug the appliance from the main socket before cleaning.
- Do not use any chemical-based solutions for cleaning fan surfaces.
- Slightly moisten a cloth and then wipe off the surfaces of the fan.
- Ensure fan is completely dry before storage or reconnecting to electrical supply.
- Never immerse the fan or fan motor in water or other liquid.
- When the fan is not in use over a long period of time, protect with a suitable cover after cleaning, then store in a dry place or dismantle and return to retail carton for winter storage.
- Use only a soft cloth to gently wipe the outer surfaces of the clean.
- To clean between the grills and fan blade area, we recommend using a pipe cleaner, flexible dust wand, vacuum cleaner or compressed air to gently remove the dust.
- To clean the grill use a soft dry cloth.
- **DO NOT** immerse the fan in water and never allow water to drip into the motor housing.
- **DO NOT** use gasoline, paint thinner or other chemicals to clean the fan.

FOR HOUSEHOLD USE ONLY
NOT INTENDED FOR COMMERCIAL USE

SPECIFICATIONS

Model: BBEC4022A

Rated voltage: 220-240V~50/60Hz

Rated power: 45W

WARRANTY

In the unlikely event that you have a problem with your Brabantia appliance, please be aware that your Brabantia appliance has a 2-year warranty.

For all enquiries, please contact the retailer you purchased this product from or the New Zealand Brabantia Agent toll free number 0800 127 727.

Warranty Exclusions

The warranty will not be valid if:

1. The product has not been installed, operated or maintained in accordance with the manufacturer's operating instructions provided with the product.
2. The product has been used for any purpose other than its intended function.
3. The damage or malfunction of the product is caused by any of the following:
 - Incorrect voltage
 - Accidents (including liquid or moisture damage)
 - Misuse or abuse of the product
 - Faulty or improper installation
 - Mains supply problems, including power spikes or lightning damage
 - Infestation by insects
 - Tampering or modification of the product by persons other than authorised service personnel
 - Exposure to abnormally corrosive materials
 - Insertion of foreign objects into the unit
 - Usage with accessories not pre-approved by Brabantia

Warning: To reduce the risk of fire or electric shock, never use the appliance together with an external electronic timer. Have any repairs carried out solely by a qualified electrician. Never try to repair the appliance yourself.

PLEASE REFER TO AND HEED ALL WARNINGS AND PRECAUTIONS IN THIS INSTRUCTION MANUAL.

DUE TO CONTINUOUS PRODUCT DEVELOPMENT, SPECIFICATIONS MAY BE SUBJECT TO CHANGE WITHOUT PRIOR NOTIFICATION.

ENVIRONMENT FRIENDLY DISPOSAL



This marking indicates that this product should not be disposed of with other household waste. To prevent possible harm to the environment or human health from uncontrolled waste disposal, recycle it responsibly to promote the sustainable re-use of material resources. To dispose of your appliance correctly, please contact or take it to your local refuse/recycling centre. Alternatively, contact your local council for information on your local re-use centre. Please make this product environmentally safe for recycling.





Manufactured by SRB Pacific Limited under
exclusive licence of Brabantia Nederland B.V.

SRB Pacific Limited,
PO Box 331260, Takapuna,
Auckland 0740, New Zealand

PRODUCT INFORMATION

BBEC4022A 79CM TOWER FAN



BRISCOES NEW ZEALAND LTD.